

Cover Specification

Origin of Materials	100% US Manufactured
Material	FDA Impact Copolymer PP
Mfg. Method	Injection Molding
Weight	.760 lbs / 345 g
Height	7/8"
Min Wall Thickness	.08"
Fitment	Buna Vent <i>Optional</i>
Standard Color	White Please inquire about custom colors
Shipping Quantity	63 per Box 504 per Pallet

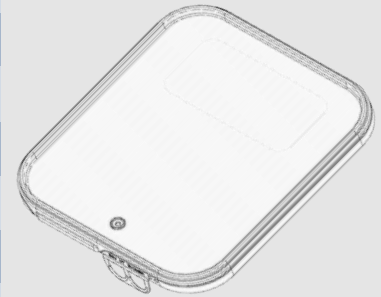

Pail Specification

Origin of Materials	100% US Manufactured
Material	FDA Impact Copolymer PP
Mfg. Method	Injection Molding
Weight	3.26 lbs. / 1483 g
Min. Wall Thickness	.095"
Exterior Height	14" With Cover 14.25"
Top Outside Diameter	12 3/8" x 14 1/2"
Bottom Outside Diameter	11 7/8" x 14"
Shipping Quantity	63 Units per Pallet 3,024 Units per Truckload
Standard Color	White <i>Please inquire about custom colors</i>
Top Load Rating	425 lbs.

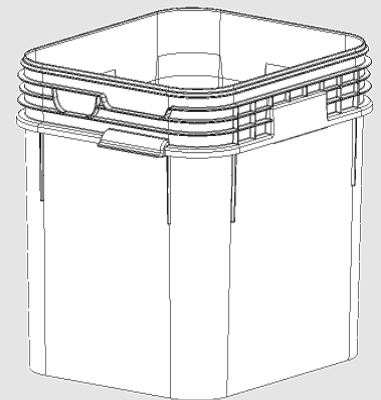

Pack Specifications For Cover

- 504 Units
- 63 per Box
- 4 Boxes per Layer x 2 High
- Lid Material is PP

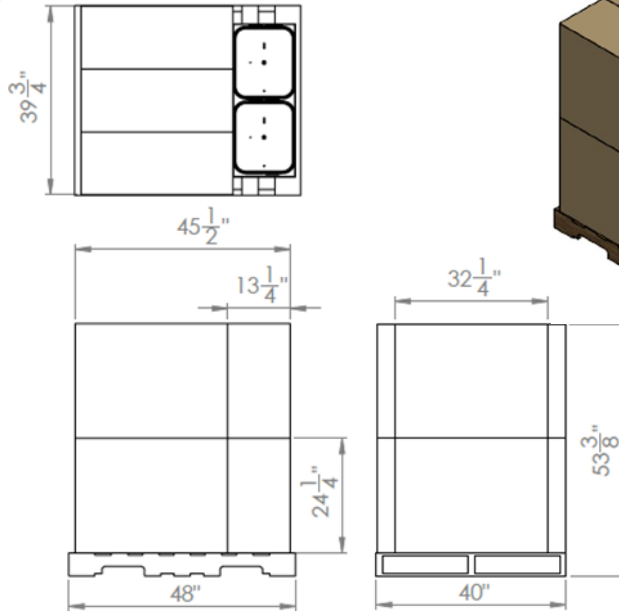

Pack Specifications For Pail

- 63 Units
- 9 Stacks x 7 High
- 3,024 Units per Truckload
- Pail Material is PP

