

**Cover Specification**

Origin of Materials	100% US Manufactured
Material	Polypropylene
Mfg. Method	Injection Molding
Weight	0.28 lbs / 130 g
Height	1 1/8"
Min Wall Thickness	.045"
Top Outside Diameter	7 3/4" x 9 5/8"
Gasket	Dry Seal
Standard Color	White <i>Please inquire about custom colors</i>
Case Quantity	144/Box, 1152/Pallet



**Pail Specification**

Origin of Materials	100% US Manufactured
Material	Polypropylene ( <i>Clarified Optional</i> ) <i>Plastic Handle</i>
Mfg. Method	Injection Molding
Weight	0.80 lbs / 362g
Min. Wall Thickness	.050"
Exterior Height	11" / 11 1/4" With Cover
Top Outside Diameter	7 1/2" x 9 3/8"
Bottom Outside Diameter	6 1/4" x 7 7/8"
Shipping Quantity	425 Units per Pallet 17,850 Units per Truckload
Standard Color	White <i>Please inquire about custom colors</i>
Print Area Decoration	9" x 28 3/4" In Mold Labeling (IML) <i>360° Unobstructed Real Estate Below Beam to Bottom Edge Including Corners</i>
Top Load Rating	100 lbs.

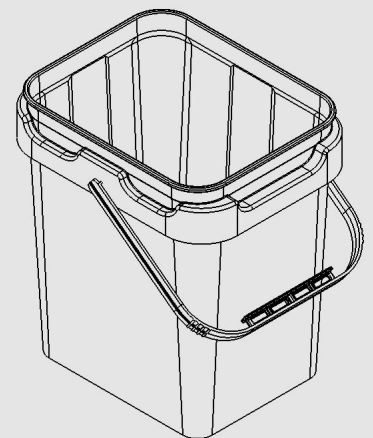

### Pack Specifications For Cover

- 1152 Units
- 144 per Box
- 4 Boxes per Layer x 2 High
- Lid Material is PP

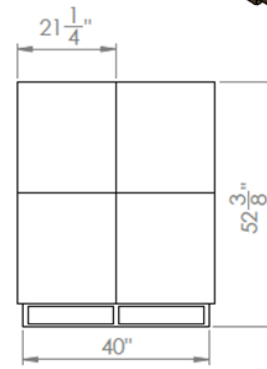
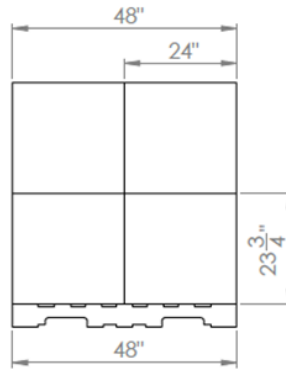
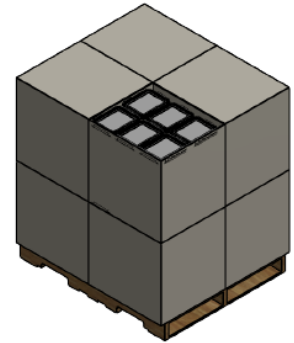
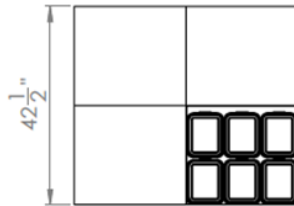

### Pack Specifications For Pail

- 425 Units
- 25 Stacks x 17 High
- 17,850 Units per Truckload
- Pail Material is PP

