

**Cover Specification**

Origin of Materials	100% US Manufactured
Material	Polypropylene
Mfg. Method	Injection Molding
Weight	.13 lbs / 60g
Height	1 1/8"
Min Wall Thickness	.03"
Top Outside Diameter	5 3/4" x 7 3/4"
Gasket	Dry Seal
Standard Color	White <i>Please inquire about custom colors</i>
Case Quantity	279/box, 2,232/Pallet



**Pail Specification**

Origin of Materials	100% US Manufactured
Material	Polypropylene ( <i>Clarified Optional</i> ) <i>Plastic Handle</i>
Mfg. Method	Injection Molding
Weight	0.29lbs / 135g
Min. Wall Thickness	.03"
Exterior Height	8 1/8" / 8 1/4" With Cover
Top Outside Diameter	5 5/8" x 7 1/4"
Bottom Outside Diameter	4 5/8" x 6 1/4"
Shipping Quantity	1,008 Units per Pallet 36,288 Units per Truckload
Standard Color	White <i>Please inquire about custom colors</i>
Print Area Decoration	6 3/4" x 22" In Mold Labeling (IML) <i>360° Unobstructed Real Estate Below Beam to Bottom Edge Including Corners</i>
Top Load Rating	60 lbs

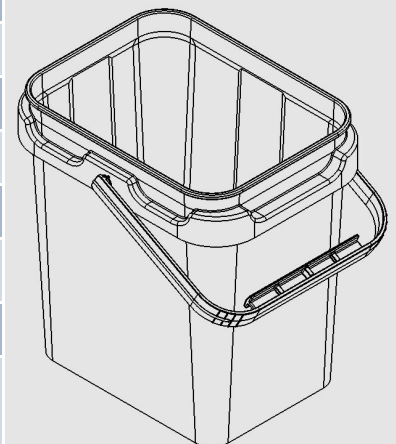

**Pack Specifications For Cover**

- 2232 Units
- 279 per Box
- 4 Boxes per Layer x 2 High
- Lid Material is PP

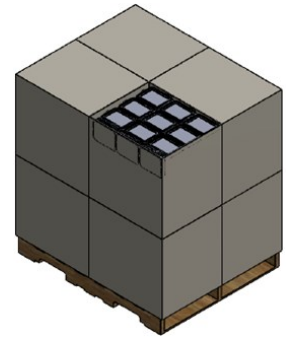
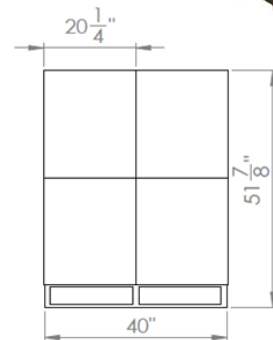
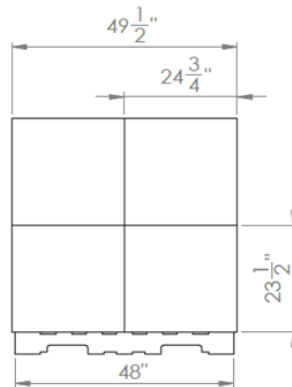
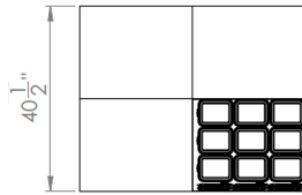

**Pack Specifications For Pail**

- 1008 Units
- 36 Stacks x 28 High
- 36,288 Units per Truckload
- Pail Material is PP

