

LID TOP VIEW

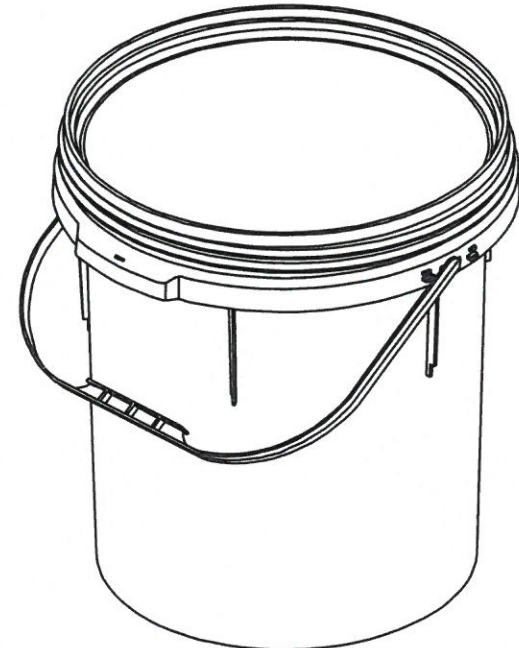

PERSPECTIVE VIEW

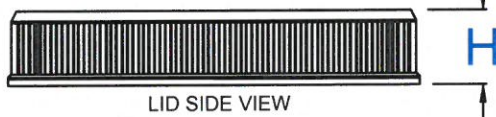
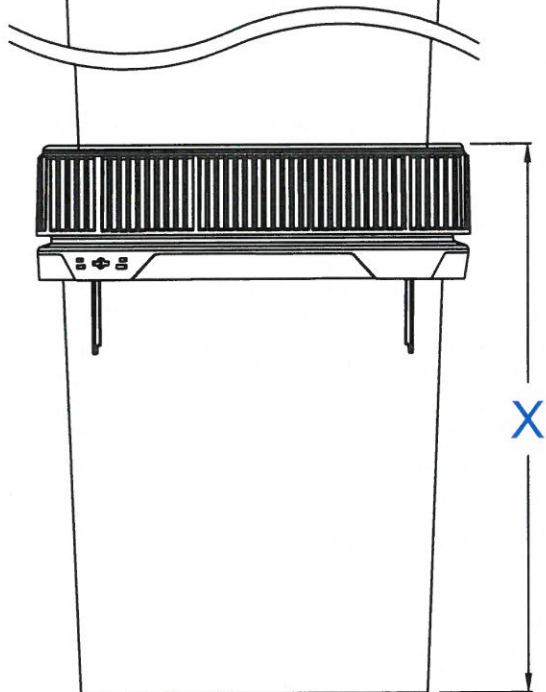

ASSEMBLY VIEW

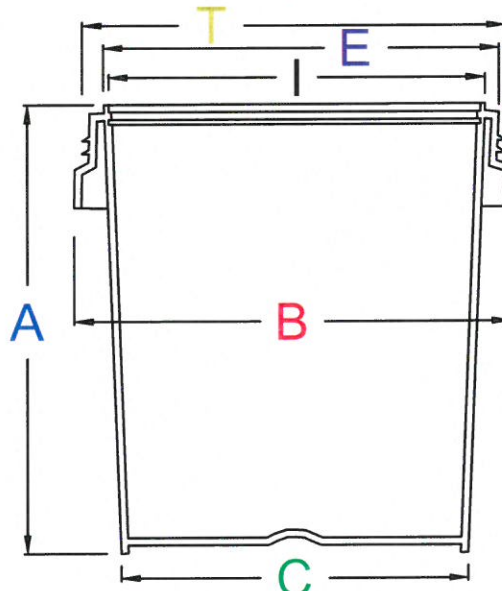

PAIL SIDE VIEW

M&M INDUSTRIES, INC.

316 Corporate Place
Chattanooga, TN 37419

Screwtop Liquid Pail

DRAWING NOT TO SCALE

Style: Screw Top Liquid Pail

Letter	Pail							Lid					Assembled pail with lid			
	(A)	(B)	(C)	(I)	(E)	(T)		(H)	(D)	(G)	(F)		(X)	(Y)	(Z)	(US gallons)
Dimension (inches-reference only)	Overall Height	Maximum Outside width of pail no handle	Bottom Outside diameter	Pail ID at top	Pail OD at top	Pail thread dimension	Minimum wall thickness	Overall Height	Outside diameter at Base	Inside diameter at base	Inside diameter at thread	Minimum wall thickness	Overall Height	Maximum diameter for palletizing no handle	Nesting depth for palletizing	Maximum fill capacity assembled
5.0 gallon	16.470	12.780	10.560	12.050	12.250	12.650	0.090	1.960	13.000	12.750	12.375	0.090	16.670	13.000	1.890	5.850