

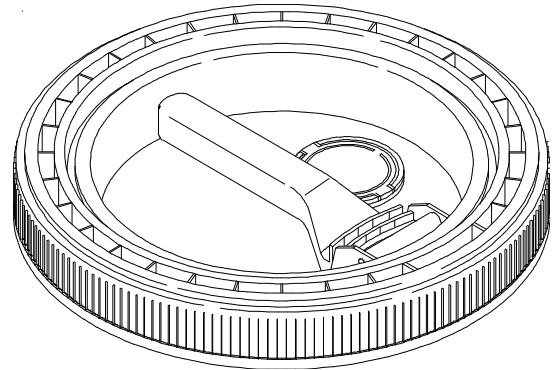

Prepared For: Standard Technical Specification  
09/08/11

### General Specifications for cover:

Material:	High Density Polyethylene (HDPE)
Method of Mfg:	Injection molding
Weight:	1.57 lbs
Cover Height:	2"
Min. Wall Thickness:	.090" (90 mil)
Top OD:	12.47"
Bottom OD:	13.07"
Fitting:	Non-spouted American Flange Plastic 38mm Spout
Case Qty:	26 per case / 312 per pallet
Standard Color:	White, Red 186, Blue 300 Please inquire about custom colors



Top ID: 12.03"

### General Specifications for Pail:

Material:	High Density Polyethylene (HDPE)
Method of Mfg:	Injection Molding
Nominal Capacity:	5.0 Gallon
Weight:	2.83 lbs
Gasket:	Neoprene
Min. Wall Thickness:	.090" (90 mil)
Exterior Height:	16.46"
Overall Height w/cover:	16.75"
Top ID:	12.03"
Bottom OD:	10.51"
Shipping case:	3 pails and lids per case
Pallet:	72
Truckload:	2,880
Handle:	Plastic
Printing area:	9" X 34.25"
Nesting:	Tapered walls for nesting
Standard Color:	White Please inquire about custom colors
UN Certification:	1H2/Y30/S & 1H2/Y1.5/30

Height  
16.46"

Height  
w/cover  
16.75"

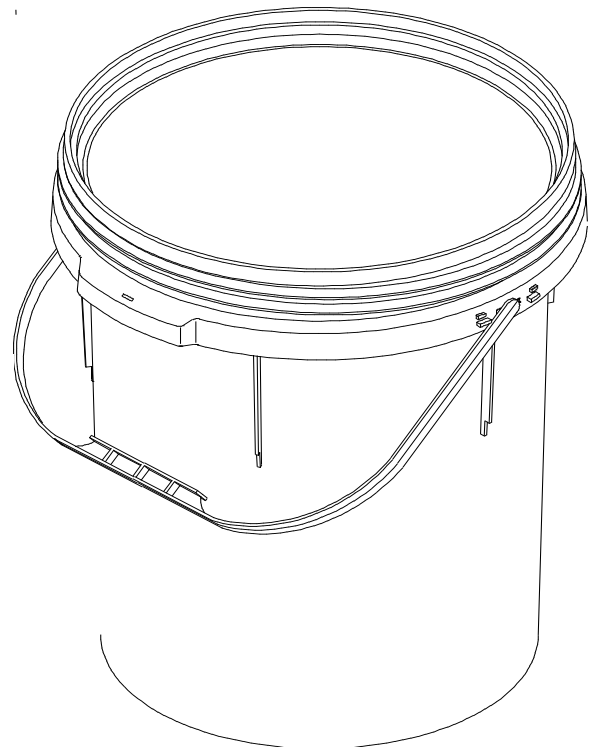

Bottom OD: 10.51"