

LID TOP VIEW

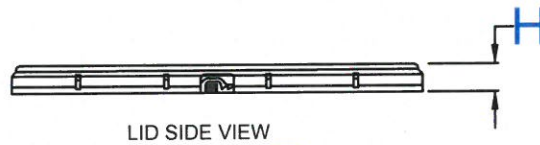

LID SIDE VIEW

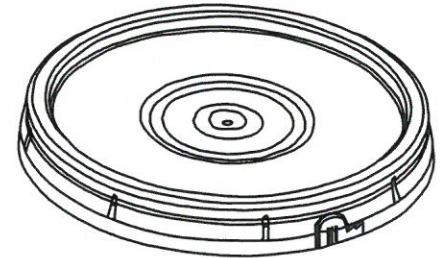

PERSPECTIVE VIEW

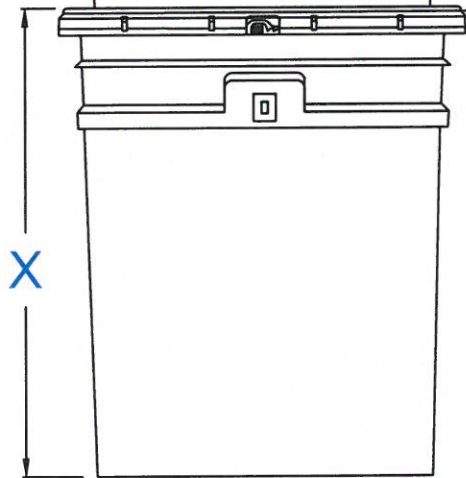

ASSEMBLY VIEW

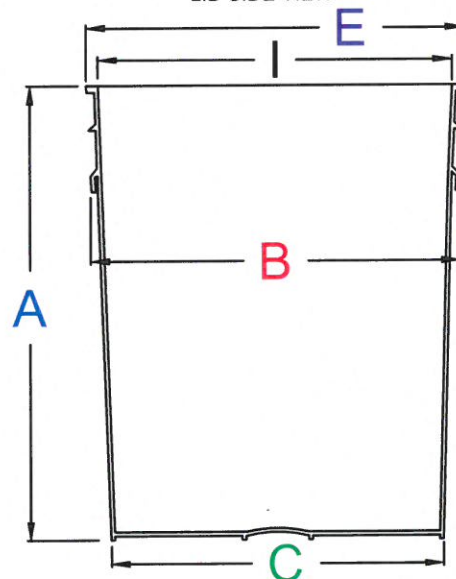

PAIL SIDE VIEW

**M&M INDUSTRIES, INC.**

316 Corporate Place  
Chattanooga, TN 37419

**M2 Traditional Pail**

DRAWING NOT TO SCALE

Style: M2 Traditional Pails

Letter	Pail						Lid				Assembled pail with lid			
	(A)	(B)	(C)	(I)	(E)		(H)	(D)	(G)		(X)	(Y)	(Z)	(US gallons)
Dimension (inches-reference only)	Overall Height	Maximum Outside width of pail no handle	Bottom Outside diameter	Pail ID at top	Pail OD at top	Minimum wall thickness	Overall Height	Outside diameter at Base	Inside diameter at base	Minimum wall thickness	Overall Height	Maximum diameter for palletizing no handle	Nesting depth for palletizing	Maximum fill capacity assembled
1.0 gallon	7.25	8.25	6.90	7.60	7.96	0.065	0.86	8.36	8.25	0.070	7.42	8.35	0.28	1.19
2.0 gallon	9.53	9.85	8.20	9.20	9.58	0.065	0.86	9.94	9.80	0.070	9.68	9.95	0.29	2.27
3.5 gallon	11.10	12.14	10.40	11.35	11.92	0.090	1.35	12.55	12.30	0.090	11.33	12.55	0.42	3.98
4.25 gallon	12.38	12.05	10.30	11.35	11.92	0.090	1.35	12.55	12.30	0.090	12.62	12.55	0.42	4.45
5.0 gallon	14.42	12.30	10.45	11.35	11.92	0.090	1.35	12.55	12.30	0.090	14.61	12.55	0.42	5.39
5.3 gallon	15.55	12.30	10.40	11.35	11.92	0.090	1.35	12.55	12.30	0.090	15.78	12.55	0.42	5.75
5.5 gallon	16.05	12.30	10.40	11.35	11.92	0.090	1.35	12.55	12.30	0.090	16.30	12.55	0.42	5.91
6.5 gallon	18.55	12.30	10.40	11.35	11.92	0.090	1.35	12.55	12.30	0.090	18.75	12.55	0.42	7.02