

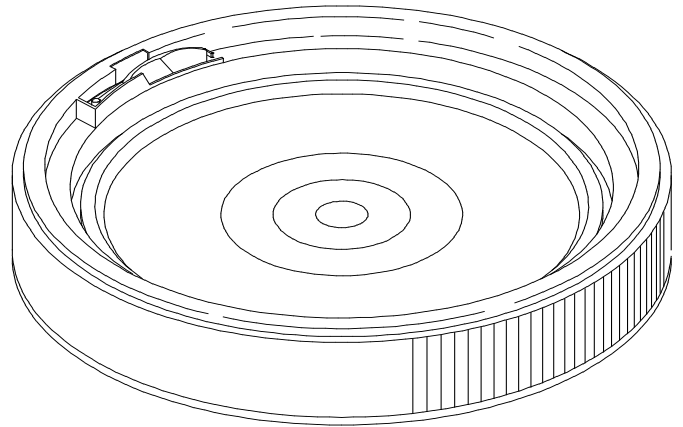

Prepared For: Standard Technical Specification 09/06/11  
Revised: 12/09/13

**General Specifications for cover:**

**Material:** High Density Polyethylene (HDPE)  
**Method of Mfg:** Injection Molding  
**Weight:** 1.03lbs/470g  
**Cover Height:** 2.50"  
**Min. Wall Thickness:** .090" (90 mil)  
**Bottom OD:** 12.690"  
**Gasket:** Neoprene  
**Qty:** 240 per pallet  
**Standard Color:** White, Red186, Blue300  
 Please inquire about custom colors



**General Specifications for Pail:**

**Material:** High Density Polyethylene (HDPE)  
**Method of Mfg:** Injection Molding  
**Nominal Capacity:** 6.5 Gallons  
**Weight:** 2.81lbs/1276g  
**Min. Wall Thickness:** .090" (90 mil)  
**Exterior Height:** 18.75"  
**Top ID:** 11.25"  
**Bottom OD:** 10.27 "  
**Shipping Case:** 2 pails and lids per case      Height  
**Pallet:** 84 units      18.75"  
**Truckload:** 3,360 units  
**Handle:** Plastic Handle  
**Printing Dimensions:** 10.5" x 33"      Height  
**Heat Transfer Dim.:** 11.438" x 31.00"      w/cover  
**Nesting:** Tapered walls for nesting      19.45"  
**Standard Color:** White  
 Please inquire about custom colors  
**UN Certification:** 1H2/Y30/S  
 1H2/X11.5/S

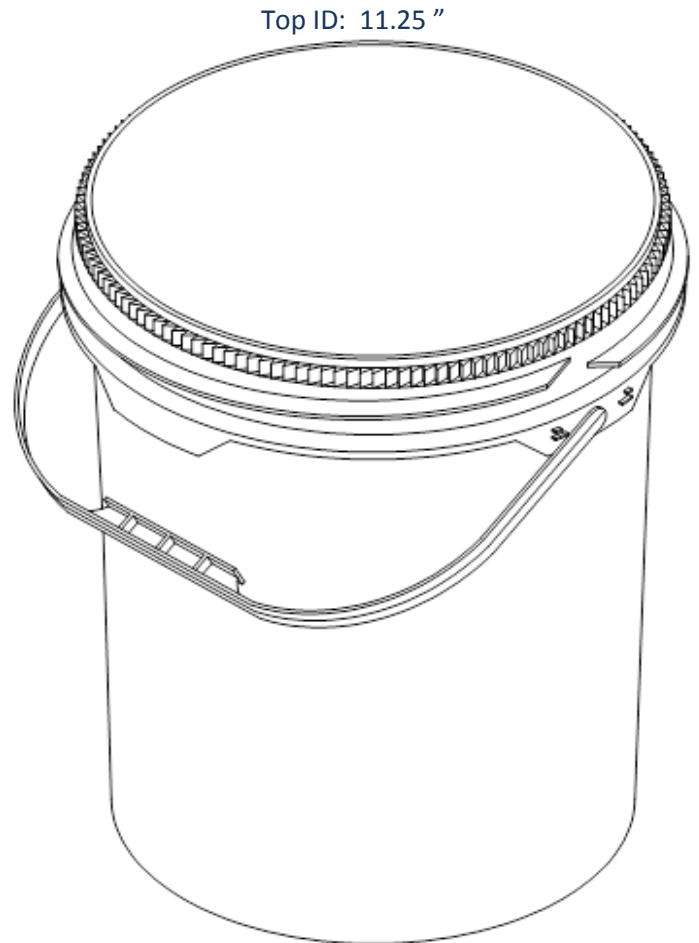

Bottom OD: 10.27"