

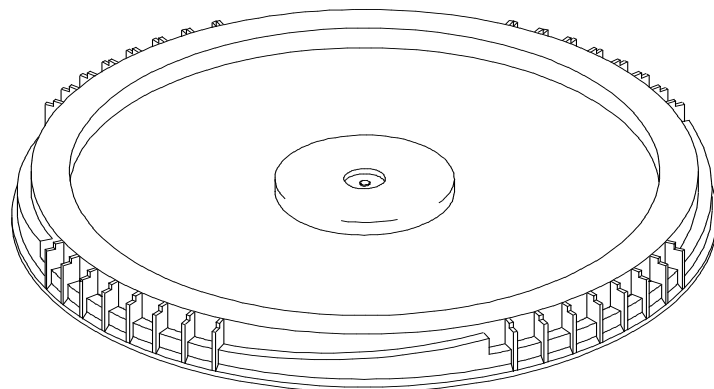

Prepared For: Standard Technical Specification 09/29/11
Revised: 3/15/17

General Specifications for cover:

Material:	High Density Polyethylene (HDPE)
Method of Mfg:	Injection Molding
Weight:	.87lbs/397g
Cover Height:	1.25"
Min. Wall Thickness:	.080" (mil)
Bottom OD:	12.603"
Gasket:	Neoprene (Available as Non-UN only)
Bulk Tray Qty:	480 per pallet
Standard Color:	White, Red 186, Blue 300
	Please inquire about custom colors



General Specifications for Pail:

Material:	High Density Polyethylene (HDPE)	
Method of Mfg:	Injection Molding	
Nominal Capacity:	5.0 Gallons	
Weight:	2.02lbs/917g	
Min. Wall Thickness:	.090" (90 mil)	
Exterior Height:	14.49"	
Top Inside Dia:	11.45"	Height
Bottom Outside Dia:	10.27"	14.49"
Pallet:	156 units	
Truckload:	6,396	
Handle:	Plastic Handle	Height
Printing Dimensions:	9.5" x 33"	w/cover
Heat Transfer Dim:	8.500" x 31.00"	14.58"
Nesting:	Tapered walls for nesting	
Standard Color:	White	
	Please inquire about custom colors	
UN Certification:	1H2/Y25/S	

