

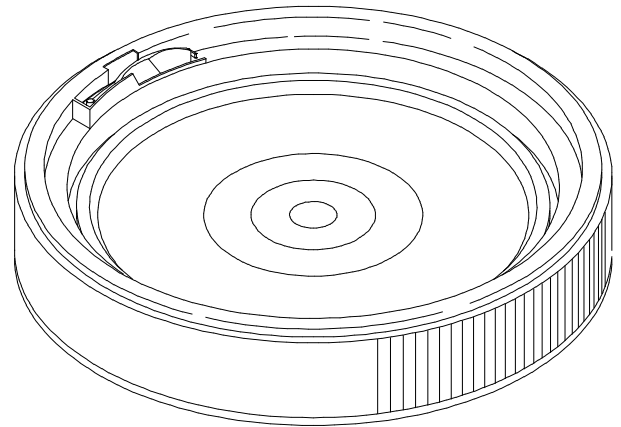

Prepared For: Standard Technical Specification 09/06/11
Revised: 3/15/17

General Specifications for cover:

Material: High Density Polyethylene (HDPE)
Method of Mfg: Injection Molding
Weight: 1.03lbs/470g
Cover Height: 2.50"
Min. Wall Thickness: .090" (90 mil)
Bottom OD: 12.690"
Gasket: Neoprene
Case Qty: 20 per case / 240 per pallet
Standard Color: White, Red186, Blue300
Please inquire about custom colors



Top ID: 11.25 "

General Specifications for Pail:

Material: High Density Polyethylene (HDPE)
Method of Mfg: Injection Molding
Nominal Capacity: 3.5 Gallons
Weight: 1.84lbs/836g
Min. Wall Thickness: .090" (90 mil)
Exterior Height: 11.50"
Top ID: 11.25 "
Bottom OD: 10.27"
Shipping: Case: 6 pails and lids per case
Pallet: 144 units
Truckload: 4,752 units
Handle: Plastic Handle
Printing Dimensions: 6.25 x 33"
Heat Transfer Dim: 6.625" x 31.750"
Nesting: Tapered walls for nesting
Standard Color: White
Please inquire about custom colors
UN Certification: 1H2/Y19/S
1H2/X16/S

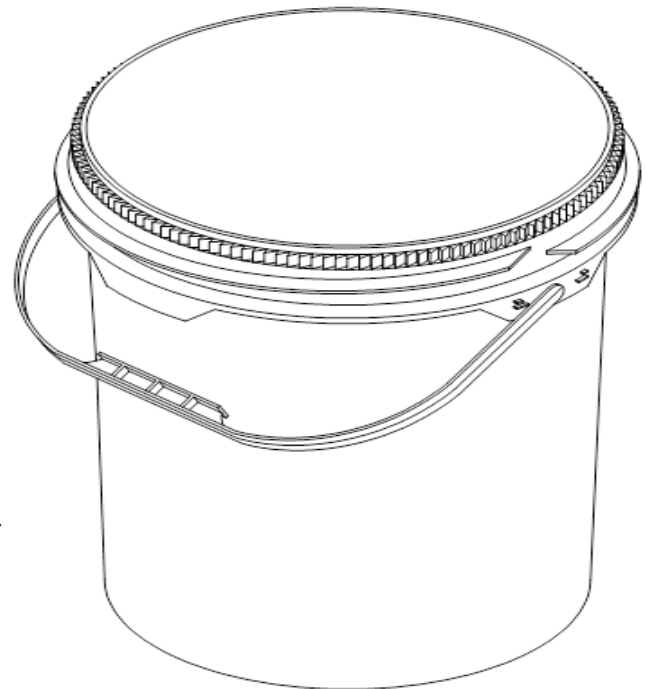

Bottom OD: 10.265"