

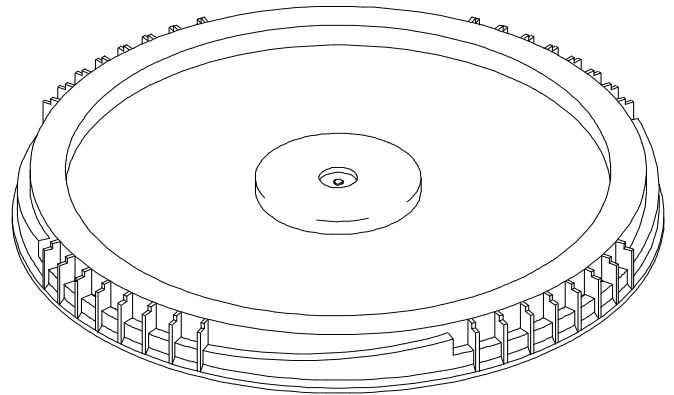

Prepared For: Standard Technical Specification 09/20/11
Revised: 3/15/17

General Specifications for cover:

Material:	High Density Polyethylene (HDPE)
Method of Mfg:	Injection Molding
Weight:	.87lbs/397g
Cover Height:	1.25"
Min. Wall Thickness:	.080" (80 mil)
Bottom OD:	12.603"
Gasket:	Neoprene (Available as Non-UN only)
Bulk Tray Qty:	480 per pallet
Standard Color:	White, Red 186, Blue 300 Please inquire about custom colors



Top ID: 11.45 "

General Specifications for Pail:

Material:	High Density Polyethylene (HDPE)	
Method of Mfg:	Injection Molding	
Nominal Capacity:	3.5 Gallons	
Weight:	1.69lbs/770g	
Min. Wall Thickness:	.090" (90 mil)	
Exterior Height:	10.99"	Height
Top Inside Dia:	11.45"	10.99"
Bottom Outside Dia:	10.37"	
Pallet:	204 units	Height
Truckload:	7,752	w/cover
Handle:	Plastic Handle	11.08"
Printing Dimensions:	6.25" x 33"	
Heat Transfer Dim:	6.625" x 31.750"	
Nesting:	Tapered walls for nesting	
Standard Color:	White Please inquire about custom colors	
UN Certification:	1H2/Y19/S	

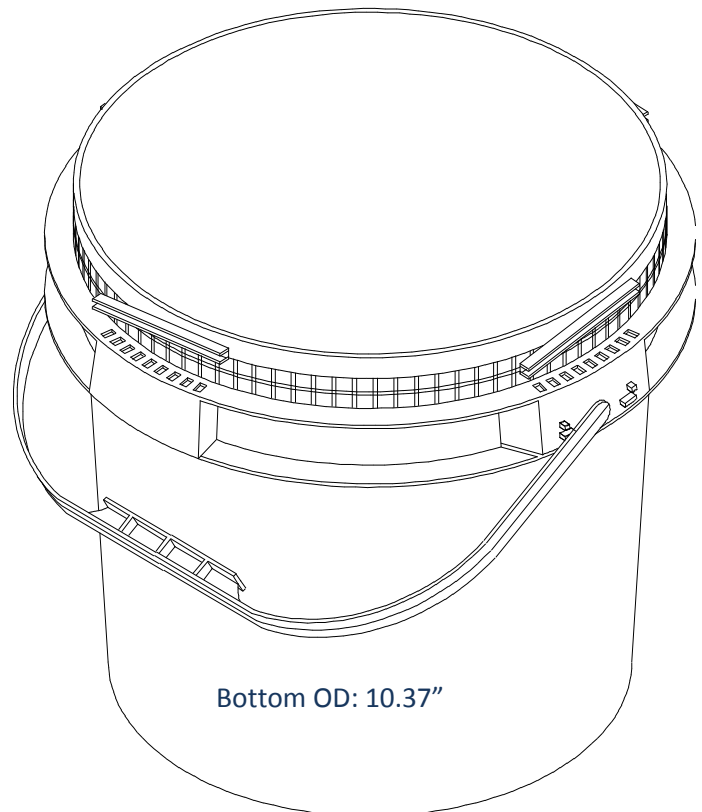

Bottom OD: 10.37"